

Graduierung geschliffener Diamanten – Teil 1: Terminologie und Klassifizierung

PAS**1048-1**

Grading polished diamonds – Part 1: Terminology and classification

Diamants taillés – Partie 1: Terminologie et classification

Vorwort

Diese öffentlich verfügbare Spezifikation (PAS = Publicly Available Specification) beschreibt die Terminologie und Klassifizierung zur Graduierung geschliffener Diamanten.

Die Spezifikation ist nur für natürliche, ungefasste, geschliffene Diamanten anwendbar.

Die PAS 1048 besteht aus 2 Teilen. In der PAS 1048-2 sind die Prüfverfahren festgelegt.

Bei Anwendung der in dieser PAS getroffenen Festlegungen wird eine Vergleichbarkeit von natürlichen, ungefassten, geschliffenen Diamanten möglich.

Der Inhalt dieser PAS wurde von der International Jewellery Confederation of National Trade Organizations (CIBJO) erarbeitet.

Die Veröffentlichung der PAS hat die Stabsabteilung Technik in Zusammenarbeit mit dem Normenausschuss Feinmechanik und Optik im DIN Deutsches Institut für Normung e. V. betreut.

Für den Inhalt dieses Dokumentes ist allein der Verfasser verantwortlich.

Verfasser ist Rudolf Biehler, München.

Auf internationaler Ebene besteht ein Technischer Report (ISO/TR 11211). Das Thema ist nicht Gegenstand eines nationalen, europäischen oder internationalen Normungsvorhabens.

Diese PAS wird nur in englischer Sprache veröffentlicht.

DIN Deutsches Institut für Normung e.V.
Stabsabteilung Technik
26. Oktober 2004

Fortsetzung Seite 2 bis 22

Foreword

This Publicly Available Specification (PAS) describes the terminology and classification of grading polished diamonds.

This specification can only be used for natural unmounted polished diamonds.

PAS 1048 consist of 2 parts. PAS 1048-2 specifies the test methods.

On application of the requirements stipulated in this PAS, a comparability of natural unmounted polished diamonds is possible.

The contents of this PAS was developed by the International Jewellery Confederation of National Trade Organizations (CIBJO).

The publication was supported by the Stabsabteilung Technik in cooperation with the Standards Committee for Optics and Precision Mechanics within the German Standards Institute (DIN).

Only the author of this document is responsible for its contents. Author is Rudolf Biehler.

On international level a Technical Report (ISO/TR 11211) exist. This subject is not part of a National, European or International standards project.

This PAS is published in English only .

Introduction

When in the 17th century – during Tavernier’s time – the diamond became an object of desire, a need for classifying this rare and diverse mineral arose. Examples of early distinctions of colours and transparencies were “First” and “Second Water”.

Later, more specific definitions were separately developed in Europe and the United States. However, ongoing Globalization required uniform classification and prompted the development of the CIBJO Rules in 1972, which were globally ratified in 1974. In 1977, IDC (International Diamond Council) adopted the concept behind these rules, but extended the proportion section by quality related parameters.

A conference in London’s Grosvenor House – including CIBJO, GIA and IDC – was held in 1988 to counter remaining discrepancies between the different classification practices. The main obstacles were GIA’s topgrade “flawless” and the IDC’s quality related proportion grades. In a compromise both items were to be abandoned. This promising formula, however, could not be realized throughout the following years.

Some years later, in a second attempt to arrive at a unified system, ISO invited the leading groups back to the table. After many years of extensive consultation ISO/TC 174 established a document, which unites the different practices in a balanced and coherent way. Its options allow an evaluation of proportions hinged on regional requirements, not taking into account the different tastes, époques, developments and fancy shapes.

All drawings, pictures and tables in this edition are documents presented to ISO 11211 WG2. The illustrations from page 14 to page 35 were presented by the Scandinavian Diamond Nomenclature Committee. We are very grateful for all the contributions and the dedication of so many colleagues.

The document at hand – building on the milestones mentioned above – offers a comprehensive and generally applicable basis for statements in diamond certificates, an essential condition for their international validity.

Contents

	Seite
1 Scope	4
2 Terms and definitions	4
3 Test report	7
4 Terminology	8
4.1 The use of the word "diamond"	8
4.2 Assembled stones	8
5 Weight and measurements	8
5.1 Weight	8
5.2 Measurements	8
6 Colour	9
6.1 General	9
6.1.1 Colourless to yellow, brown and grey (D to Z)	9
6.1.2 All other colours	9
6.2 Colour grades (colourless to yellow, brown and grey)	9
6.3 Colour grades (other than for yellow, brown and grey)	9
6.4 Fluorescence	11
7 Clarity	12
7.1 General	12
7.2 Clarity grades	12
7.3 Clarity characteristics	12
7.4 Laser drilling	12
8 Cut	14
8.1 Cut characteristics	14
8.2 Shape	14
8.3 Proportions	14
8.3.1 Description	14
8.3.2 Girdle diameter (used as a basis for descriptions of proportions)	15
8.3.3 Table size (percentage)	15
8.3.4 Crown height (percentage) and/or crown angle (degrees)	15
8.3.5 Pavilion depth (percentage) and/or pavilion angle (degrees)	15
8.3.6 Girdle thickness (percentage or description)	15
8.3.7 Culet size (percentage or description)	16
8.3.8 Total depth/height	16
8.3.9 Proportions comment	16
8.4 Finish	16
8.4.1 Polish	20
8.4.2 Symmetry	20
Annex A (normative) Clarity, polish and symmetry characteristics	21

1 Scope

This document specifies the terminology and classification that shall be used for the grading and description of polished diamonds.

This document shall only be used for natural, unmounted, polished diamonds. It shall not be used for synthetic diamonds (see 2.2), treated diamonds (see 2.3) (other than is allowed for in 7.4), nor for assembled stones (see 2.5).

2 Terms and definitions

For the purposes of this part of PAS 1048, the following terms and definitions apply.

2.1 diamond

natural mineral consisting essentially of carbon crystallized in the isometric (cubic) crystal system, with a Mohs' scale hardness of 10, a specific gravity of approximately 3,52, and a refractive index, n_D , of 2,417

2.2 synthetic diamond

man-made reproduction of diamond (2.1) that has essentially the same chemical composition, crystal structure, optical and physical properties as its natural counterpart

2.3 treated diamond

diamonds (2.1) treated, other than by cutting, polishing and cleaning, to change the diamond's appearance by coating, filling, heating, irradiation, or any other physical or chemical treatment

2.4 polished diamond

diamonds (2.1) with a defined cut (2.12)

2.5 assembled stone

stone constructed of two or more parts of which at least one is diamond (2.1), synthetic diamond (2.2) or treated diamond (2.3)

2.6 colour

relative absence (colourlessness) or presence of hue

2.7 fluorescence

degree of luminescence of a diamond (2.1) when viewed under a long-wave ultraviolet (UV) light source with a wavelength of 365 nm

2.8 clarity

relative degree to which a diamond (2.1) is free from internal characteristics /inclusions (3.9) and external characteristics /blemishes (2.10)

2.9 Internal characteristics/inclusions

2.9.1 bearding

tiny feathers extending in from the girdle

2.9.2

bruise

surface percussion mark, often accompanied by tiny, root-like feathers

2.9.3

cavity

large or deep opening

2.9.4

chip

relatively shallow indentation, usually occurring along the girdle or culet (could also be external)

2.9.5

cleavage

large feather occurring in a plane, parallel to a crystal face

2.9.6

cloud

hazy or milky area made up of a number of very small inclusions

2.9.7

crystal

mineral crystal included in a diamond

2.9.8

feather

fracture

separation or break due to either cleavage or fracture, often white and feathery in appearance

2.9.9

grain centre

small area of concentrated crystal structure distortion

2.9.10

graining

internal indications of irregular crystal growth

2.9.10.1

coloured graining

graining which appears as coloured streaks

2.9.10.2

reflective graining

graining which appears as reflective plane

2.9.10.3

whitish graining

graining which may appear as whitish streaks or may give the stone a hazy (cloudy appearance which decreases transparency

2.9.11

intended natural

a natural that penetrates the stone

NOTE It might be considered an external characteristic depending upon depth

2.9.12

knot

included diamond crystal which reaches the surface

2.9.13

laser drill hole

tiny tube made by a laser; the surface opening may resemble a pit, while the tube usually looks needle-like

2.9.14

needle

long, thin included crystal which looks like a tiny rod

2.9.15

nick

notch near the girdle or a facet edge – may be considered as an internal characteristic depending upon depth

2.9.16

pinpoint

very small inclusion; under 10 × normally seen as a tiny dot, either singly or in groups or strings

2.9.17

reduced transparency

cloudy, milky, or hazy appearance of the whole or part of a diamond due to internal features that may or may not be visible at 10 × magnification

2.9.18

twinning wisp

inclusions located in a plane, which occur as a result of the change in orientation of the diamond crystal structure

2.10 External characteristics/blemishes

2.10.1

abrasion

tiny nicks along facet junction's or culet, producing white fuzzy lines instead of sharp facet edges

2.10.2

bruting lines

tiny lines on a girdle not displaying a feather-like appearance

2.10.3

burn mark

surface clouding caused by excessive heat, or uneven polished surface

2.10.4

chip

relatively shallow indentation, usually occurring along the girdle or culet (could also be internal)

2.10.5

extra facet

facet placed without regard for symmetry and not required by the cutting style

2.10.6

natural

part of the original crystal surface remaining on the polished stone

2.10.7

nick

notch near the girdle or a facet edge; may be considered as an internal characteristic depending upon depth

2.10.8

pit

tiny opening, often looking like a white dot

2.10.9

polish line

tiny parallel lines left by polishing; fine parallel ridges confined to single facet, caused by crystal structure irregularities; or tiny, parallel, polished grooves produced by irregularities in the scarify surface

2.10.10

pitted girdle

very rough bruted girdle surface

2.10.11

scratch

linear indentation normally seen as a fine white line, curved, or straight

2.10.12

surface grain line

surface indication of structural irregularity which is not seen internally; may resemble faint facet-junction lines, or cause a grooved or wavy surface; often the lines cross facet junctions

2.11

naked eye

naked (unaided) eye, or visible to the eye through glasses adjusting an anomalous eyesight to normal

2.12

cut

shape, proportions and finish of a diamond (2.1)

2.13

shape/form

outline of a diamond when viewed perpendicular to the table facet

2.14

weight

mass of a diamond (2.1)

2.15

diamond loupe

an achromatic and aplanatic, triplet type, 10 × magnifying lens. The frame of the loupe shall be of a neutral 'colour'

3 Test report

A description of a polished diamond (see 2.4) shall be established by grading its criteria in accordance with the rules specified in clauses 4 to 8 inclusive. The test report shall contain at least the following information:

- reference to this PAS 1048;
- the results of the tests specified in this PAS 1048;
- clarity;
- colour;
- comments (if applicable);
- long wave ultra violet fluorescence;
- measurements;
- plot of internal characteristics /inclusions and external characteristics/blemishes;

- proportions (table size, crown height, and or crown angle, pavilion depth and/or pavilion angle, and/or total depth, girdle thickness, culet size);
- reference code;
- shape and cut;
- symmetry;
- weight;
- the date of the test.

4 Terminology

4.1 The use of the word “diamond”

It is unnecessary to note the genesis of a diamond (2.1), as the use of the word “diamond” alone and without qualification states that it is natural.

The word “diamond” (2.1) alone shall not be used to describe synthetic diamonds (2.2) no matter which basic material or methods are used. Products made in this way shall be clearly referred to as “synthetic diamond” and shall not be graded.

4.2 Assembled stones

Assembled stones (2.5) shall be clearly identified and shall not be graded.

5 Weight and measurements

5.1 Weight

The weight of a diamond (2.13) shall be expressed in metric carats (ct), one carat is equivalent to 200 mg (1/5 g). The weight of a diamond shall be stated in carats to two decimal places.

NOTE It is acceptable verbally to express one-hundredth of a carat as a “point”.

Weight shall be rounded upwards if the third decimal is a 9, for example:

- 0,996 → 0,99 ct
- 0,998 → 0,99 ct
- 0,999 → 1,00 ct

NOTE Weight may be stated to three decimal places if the accuracy of the weighing equipment is accurate to this degree.

5.2 Measurements

The measurements of a diamond shall be expressed in millimetres to two decimal places.

The following measurements shall be contained in the test report (see clause 3):

- round shape: minimum diameter, maximum diameter and depth (total height);
- fancy shape: length, width and depth (total height). Length shall be the maximum measurement in the vertical line of the plotted diagram and width shall be the maximum measurement in the horizontal line of the plotted diagram.

6 Colour

6.1 General

Diamond colours shall be divided into the following two main categories (6.1.1 and 6.1.2).

NOTE For both main categories (6.1.1 and 6.1.2), photometric measurements intended for colour grade determination have no conclusive value.

6.1.1 Colourless to yellow, brown and grey (D to Z)

The colour of diamond within the D to Z grade range shall be determined by visual comparison with a series of masterstones approved by CIBJO on 27 April 1978 as the official set of masterstones for determining the colour grades. The determination shall be carried out by a trained observer with normal eyesight (see 2.11) and colour discrimination, under an artificial light source, the specification for which ranges from D₅₅ to D₆₅ [International Commission on Illumination (CIE) standard illuminant].

The colour grade shall be described by the letter or letter range between D and Z, (in capital letters) with or without the colour corresponding terms in tables 1 and 2.

6.1.2 All other colours

Apart from those diamonds referred to in 6.1.1 there are those diamonds that are darker in tone and/or higher in saturation than Z and diamonds with other noticeable hues or tones and these are coloured diamonds. In this category, the specific term “fancy” shall precede the colour description of a coloured diamond.

6.2 Colour grades (colourless to yellow, brown and grey)

The colour grades that shall be used are given in table 1.

The German, French, Italian and Scandinavian equivalent terms shall be as given in table 2.

6.3 Colour grades (other than for yellow, brown and grey)

Diamonds with colours other than yellow, brown or grey, in which the colour is not visible in the face-up position, shall be graded in accordance with the colour grading scale (see table 1).

The grade shall be described either with the letter grade or by stating the term “faint” followed by the hue, or by both.

Table 1 — Colour grading scale

Exceptional white +	D
Exceptional white	E
Rare white +	F
Rare white	G
White	H
Slightly tinted white	I
Slightly tinted white	J
Tinted white	K
Tinted white	L
Tinted	M
	N
	O
	P
	Q
	R
	S
	T
	U
	V
	W
X	
Y	
Z	
<p>NOTE 1 For diamonds weighing under 0.47 ct, the grades D EW+ and E EW may be combined into one grade as Exceptional White or D-E, and the grades F RW+ and G RW may be combined into one grade as Rare White or F-G.</p> <p>NOTE 2 Combined letter grades including and below I may be used.</p> <p>NOTE 3 For grades I to L the term “equivalent colour grade” may be used in conjunction with the letter grade for those diamonds that have brown or grey present.</p> <p>NOTE 4 Descriptions indicating the presence of brown or grey may be given for Grades M and below with or without using the letter grades if the hue / tone description is prefixed with “light”.</p>	

Table 2 – Corresponding terms for colour grades

GIA	CIBJO/IDC						Scan.D.N	
	English	German	French	Italian				
D	Exceptional white +	Hochfeines Weiss+	Blanc exceptionnel +	Bianco extra eccezionale+	River	D	D	
E	Exceptional white	Hochfeines Weiss	Blanc exceptionnel	Bianco extra eccezionale	River	E	E	
F	Rare white +	Feines Weiss +	Blanc extra +	Bianco extra +	Top Wesselton	F	F	
G	Rare white	Feines Weiss	Blanc extra	Bianco extra	Top Wesselton	G	G	
H	White	Weiss	Blanc	Bianco	Wesselton	H	H	
I	Slightly tinted white	Leicht getöntes Weiss	Blanc nuancé	Bianco sfumato	Top crystal	I	I	
J	Slightly tinted white	Leicht getöntes Weiss	Blanc nuancé	Bianco sfumato	Crystal	J	J	
K	Tinted white	Getöntes Weiss	Légèrement teinté	Bianco leggermente colorito	Top cape	K	K	
L	Tinted white	Getöntes Weiss	Légèrement teinté	Bianco leggermente colorito	Cape	L	L	
M					Cape	M	M	
N					Cape	N	N	
O					Cape	O	O	
P					Cape	P	P	
Q					Cape	Q	Q	
R					Cape	R	R	
S					Cape	S	S	
T	Tinted	Getönt	Teinté	Colorito	Cape	T	T	
U					Cape	U	U	
V					Cape	V	V	
W					Cape	W	W	
X					Cape	X	X	
Y					Cape	Y	Y	
Z					Cape	Z	Z	

6.4 Fluorescence

Fluorescence shall be determined by comparison with a series of 3 Cibjo approved reference stones.

The degree of fluorescence shall be characterized in accordance with table 3.

Table 3 — Description of degree of fluorescence

None or nil
Faint or slight
Medium
Strong

NOTE The colour of fluorescence may be mentioned together with the degree of fluorescence.

7 Clarity

7.1 General

Clarity shall be determined by a trained observer with normal eyesight (see 2.11) using achromatic and aplanatic 10 × magnification, under an artificial source of light, the specification of which is D₅₅ to D₆₅ (CIE standard illuminant).

The following aspects of the internal characteristics/inclusions and external characteristics/blemishes shall be considered when determining the clarity grade:

- size
- nature
- number
- position
- brightness/colour
- mirrored images

NOTE Diamonds that are beyond the I3 / P3 grade are known as rejection grade and are considered as being outside the clarity grading scale.

7.2 Clarity grades

The clarity grades shall be distinguished and defined in accordance with tables 4 and 5.

7.3 Clarity characteristics

Clarity shall be considered in accordance with tables 4 and 5 and annex A (A.1 and A.2) see definitions 2.9 and 2.10.

7.4 Laser drilling

All diamonds that have been drilled with a laser shall be referred to as “Laser Drilled”, and can be graded. No other treated diamonds shall be graded.

Table 4 — Clarity characteristics

<p style="text-align: center;">Flawless (FL)</p> <p>FL diamonds shall be free from internal characteristics/inclusions and external characteristics/ blemishes when examined under 10 × magnification.</p> <p>NOTE The following do not disqualify a diamond from the Flawless Grade:</p> <ul style="list-style-type: none"> — an extra facet on the pavilion which cannot be seen face up; — naturals totally confined to the girdle, which neither thicken the girdle nor distort its outline; — internal graining which is not reflective, white or coloured and does not significantly affect transparency. 	<p style="text-align: center;">Loupe Clean (LC)</p> <p>LC diamonds shall be free from internal characteristics/inclusions when examined under 10 × magnification.</p> <p>NOTE The following does not disqualify a diamond from the Loupe Clean grade:</p> <ul style="list-style-type: none"> — Internal graining which is not reflective, white or coloured and does not significantly affect transparency.
<p style="text-align: center;">Internally Flawless (IF)</p> <p>If diamonds shall be free from internal characteristics/inclusions and shall only possess external characteristics / blemishes when examined under 10 × magnification.</p> <p>NOTE The following does not disqualify a diamond from the Internally Flawless grade:</p> <ul style="list-style-type: none"> — Internal graining which is not reflective, white or coloured and does not significantly affect transparency. 	
<p style="text-align: center;">Very Very Slightly Included/Very Very Small Inclusions (VVS)</p> <p>VVS diamonds shall contain minute internal characteristics/inclusions when examined under 10 × magnification.</p> <p>VVS1 diamonds shall contain minute internal characteristics/inclusions which shall be extremely difficult to observe when examined under 10 × magnification.</p> <p>VVS2 diamonds shall contain minute internal characteristics/inclusions which shall be very difficult to observe when examined under 10 × magnification.</p>	
<p style="text-align: center;">Very Slightly Included/Very Small Inclusions (VS)</p> <p>VS diamonds shall contain minor internal characteristics/inclusions when examined under 10 × magnification.</p> <p>VS1 diamonds shall contain minor internal characteristics/inclusions which shall be difficult to observe when examined under 10 × magnification.</p> <p>VS2 diamonds shall contain minor internal characteristics/inclusions which shall be somewhat easy to observe under 10 × magnification.</p>	
<p style="text-align: center;">Slightly Included/Small Inclusions (SI)</p> <p>SI diamonds shall contain noticeable internal characteristics/inclusions when examined under 10 × magnification.</p> <p>SI1 diamonds shall contain noticeable internal characteristics/inclusions which shall be easy to observe when examined under 10 × magnification.</p> <p>SI2 diamonds shall contain noticeable internal characteristics/inclusions which shall be very easy to observe when examined under 10 × magnification.</p>	
<p style="text-align: center;">Included 1 or Pique 1 (I1/P1)</p> <p>I1/P1 diamonds shall contain internal characteristics/inclusions which are prominent when examined under 10 × magnification. They shall also be visible face up to the naked eye.</p> <p>NOTE Under certain circumstances, internal characteristics/inclusions may also be visible face up to the naked eye in higher grades.</p>	
<p style="text-align: center;">Included 2 or Pique 2 (I2 / P2)</p> <p>I2/P2 diamonds shall contain internal characteristics/inclusions which are very prominent when examined under 10 × magnification. They shall also be easily visible face up to the naked eye, slightly reducing the brilliancy of the diamond.</p>	
<p style="text-align: center;">Included 3 or Pique 3 (I3 / P3)</p> <p>I3/P3 diamonds shall contain internal characteristics/inclusions which are extremely prominent when examined under 10 × magnification. They shall also be very easily visible face up to the naked eye, reducing the brilliancy of the diamond.</p>	

Table 5 — Clarity grades

LC	FL	
	IF	
VVS1		VVS
VVS2		
VS1		VS
VS2		
S11		SI
S12		
P1 or I1		
P2 or I2		
P3 or I3		
NOTE The grades shaded in grey may be used for diamonds weighing under 0.47ct.		

8 Cut

8.1 Cut characteristics

Cut shall be categorized by the following characteristics:

- a) the outline of the diamond combined with the facet arrangement.
- b) proportions: the relationships between the various parts of a diamond and the girdle diameter.
- c) finish: the quality of the surface condition of a diamond, the exactness of its shape and the arrangement of the facets.

8.2 Shape

Common diamond shapes are illustrated in figure 1. A variety of other shapes exist and these shall be clearly described in detail.

The term “brilliant” without any additional description shall only be applied to round brilliant cut diamonds.

NOTE The term “fancy shape” is generally used to describe all shapes other than round.

The various parts and the facet arrangement of a round brilliant are explained in figure 2.

8.3 Proportions

8.3.1 Description

The proportions (see Figure 3) described in 8.3.2 to 8.3.9 shall be included in the test report of a diamond.

8.3.2 Girdle diameter (used as a basis for descriptions of proportions)

The girdle diameter shall be the average of at least four measurements of the girdle diameter at different points for rounds, and shall be the width for fancy shapes.

8.3.3 Table size (percentage)

The table size shall be the average size of the table facet, expressed as a percentage of the average girdle diameter.

For round stones measurements to describe the table size shall be made from opposite corner to corner and expressed as an average of the four possible measurements. For fancy shapes table size measurements shall be taken when viewing the profile of the diamond along its length (see figures 1 and 2).

8.3.4 Crown height (percentage) and/or crown angle (degrees)

For round stones the crown height shall be the average of eight measurements reflecting the distance from the upper girdle level to the level of the table facet, measured where the bezel/upper main facets and upper girdle level meet, and expressed as a percentage of the girdle diameter.

The crown angle shall be the average angle formed where the bezel/upper main facets and upper girdle plane meet, expressed in degrees.

For fancy shapes the crown height and angle measurements shall be taken when viewing the profile of the diamond along its length (see figure 1).

8.3.5 Pavilion depth (percentage) and/or pavilion angle (degrees)

For round stones the pavilion depth shall be the average of eight measurements reflecting the distance from the lower girdle level to the level of the culet, measured where the pavilion/lower main facets meet the lower girdle level, and expressed as a percentage of the girdle diameter.

The pavilion angle shall be the average angle formed where the pavilion/lower main facets and lower girdle plane meet, expressed in degrees.

For fancy shapes the pavilion depth and angle measurements shall be taken when viewing the profile of the diamond along its length.

Optionally crown height and pavilion depth can be combined to total depth and expressed as a percentage of the girdle diameter.

8.3.6 Girdle thickness (percentage or description)

The thickness of the girdle can be the average of eight measurements reflecting the distance between the levels where the related lower and upper main facets meet the girdle and shall be expressed as a percentage of the girdle diameter, noting the minimum and maximum and/or the average percentage.

Optionally a description as “thin”, “medium” or “thick” can be given instead.

A description of the nature of the girdle shall be noted if it is not bruted, as follows:

- faceted,
- polished.

For fancy shapes girdle thickness measurements shall be taken when viewing the profile of the diamond along its length.

8.3.7 Culet size (percentage or description)

The culet size can be expressed as a percentage of the girdle diameter.

Optionally a description as “pointed”, “small” and “large” can be given instead.

The culet size can be the culet diameter for round stones or the culet width for fancy shapes (see 5.2).

A description of the nature of the culet shall be added as, “pointed”, “polished”, “natural”, or “linear”.

8.3.8 Total depth/height

The total depth shall be the distance between the table facet and the culet, expressed as a percentage of the girdle diameter.

8.3.9 Proportions comment

A comment describing the proportion parameters of round brilliant cut diamonds can be given in accordance with the criteria set out in PAS 1048-2, clause 8.3 and table 4.

8.4 Finish

Finish includes the polish and symmetry categories. The external characteristics/blemishes which shall be taken into consideration under polish or symmetry are listed in Annex A (A.3 and A.4). They shall also be taken into consideration for clarity determination but only to distinguish between “flawless” and “internally flawless”.

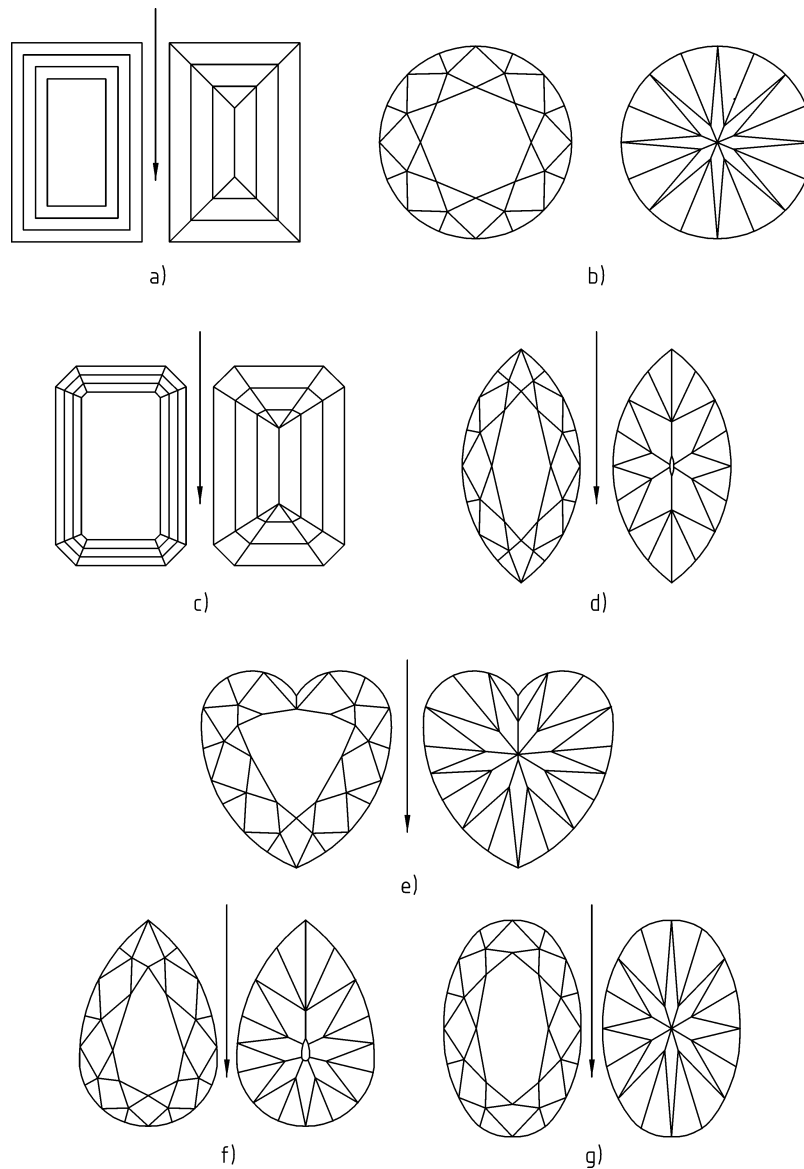

Key

- a) Rectangular
- b) Round
- c) Octagonal
- d) Marquise
- e) Heart
- f) Pear
- g) Oval

The downward arrows indicate the direction in which fancy cut stones shall be viewed when determining crown height.

Figure 1 — Common diamond shapes, cuts, and typical facet arrangements

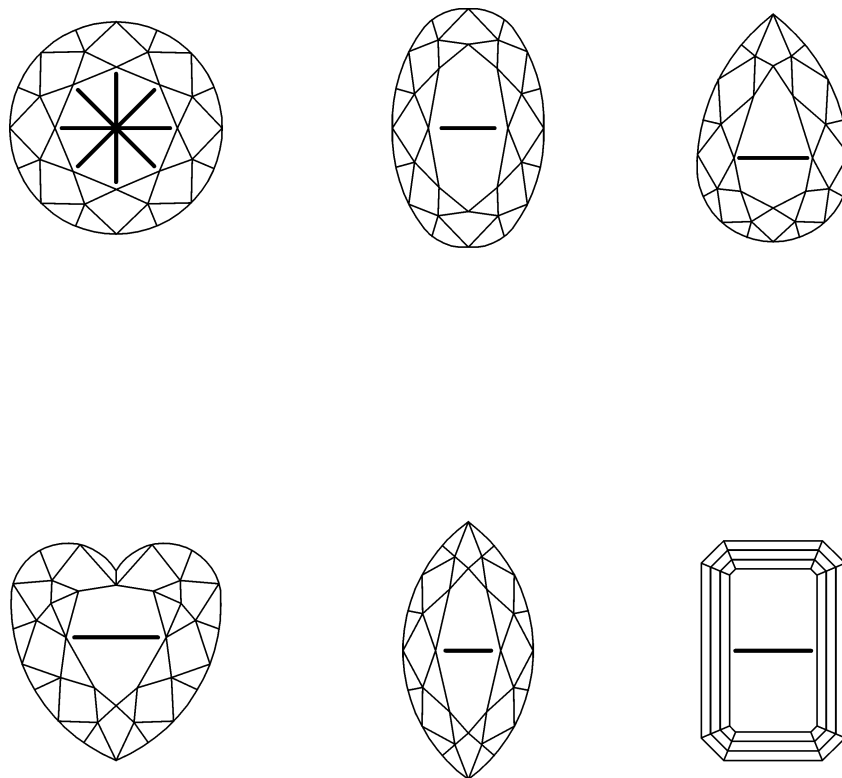

The thick lines indicates the directions in which table size shall be determined.

Figure 2 — Common diamond shapes, cuts, and typical facet arrangements

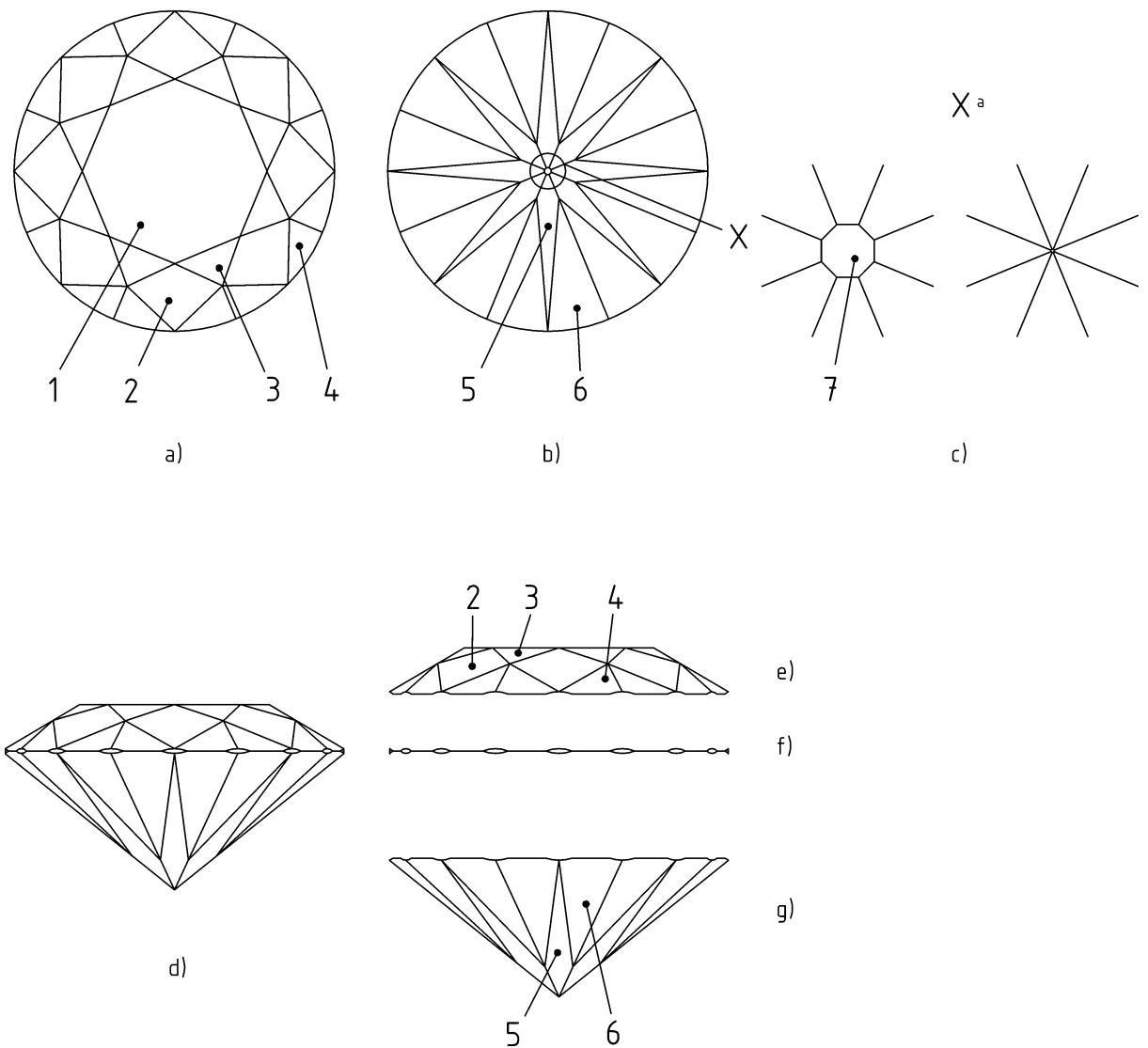

Key

**Designation
facets**

Facet name

**Number of
facets**

a)	Crown view	1	Table	1
b)	Pavilion view	2	Bezel/Upper main	8
c)	Culet (enlarged)	3	Star	8
d)	Profile view	4	Upper girdle/Upper halves	16
e)	Crown	5	Pavilion main/Lower main	8
f)	Girdle	6	Lower girdle/Lower halves	16
g)	Pavillion	7	Culet	0 or 1
			Total number of facets	57 or 58

Figure 3 — Parts and facet arrangement of a round brilliant

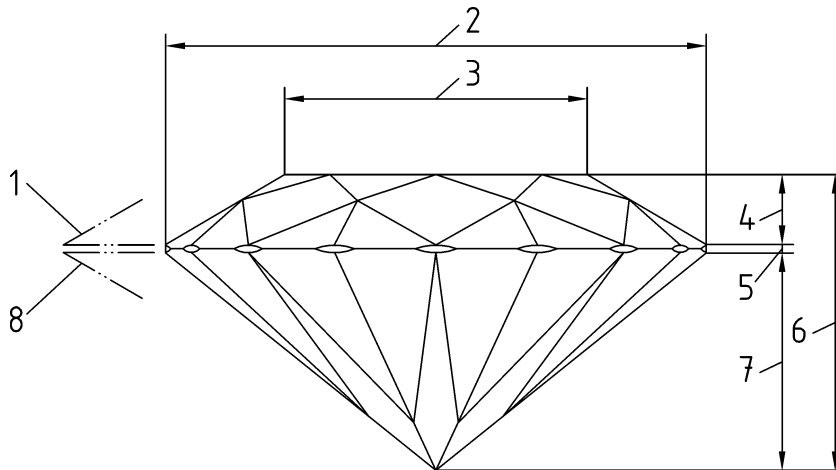

Key

- | | | | |
|---|-----------------|---|------------------|
| 1 | Crown angle | 5 | Girdle thickness |
| 2 | Girdle diameter | 6 | Total depth |
| 3 | Table size | 7 | Pavillion depth |
| 4 | Crown height | 8 | Pavillion angle |

Figure 4 — Proportions involved in the description of a diamond

8.4.1 Polish

Polish refers to the quality of the facet surface condition and, as an option may be, graded according to the following categories:

- very good;
- good;
- fair/medium;
- poor.

NOTE An optional grade of excellent may be used.

8.4.2 Symmetry

Symmetry refers to the exactness of the shape of a diamond and the arrangement of the facets and shall be graded according to the following categories:

- very good;
- good;
- fair/medium;
- poor.

NOTE An optional grade of excellent may be used.

When grading symmetry, examples of major deviations that shall be taken into consideration are as follows:

- imperfect roundness/uneven outline;
- variation of crown height;
- deviation of the central table position;
- deviation of the central culet position;
- wavy girdle.

Annex A (normative)

Clarity, polish and symmetry characteristics

A.1 The following may be considered as internal characteristics/inclusions (see definitions in clause 2.9):

- bearding;
- bruise;
- cavity;
- chip;
- cleavage;
- cloud;
- crystal;
- feather;
- fracture;
- grain centre;
- graining;
- indented natural;
- knot;
- laser drill hole;
- needle;
- nick;
- pinpoint;
- reduced transparency;
- twinning wisp.

A.2 The following may be considered as external characteristics/blemishes (see definitions in clause 2.10):

- abrasion;
- bruting lines;
- burn mark;
- chip;
- extra facet;
- natural;
- nick;
- pit;
- polish line;
- pitted girdle;
- scratch;
- surface grain line.

A.3 The following characteristics shall be taken into consideration for polish determination:

- abrasion;
- bruting line;
- burn mark;
- nick;
- pit;
- polish line;
- pitted girdle;
- scratch.

These characteristics shall also be taken into account for clarity determination, when distinguishing between “flawless” and “internally flawless”.

A.4 The following characteristics shall be taken into consideration for symmetry determination:

- extra facet;
- natural.

These characteristics shall also be taken into account for clarity determination, when distinguishing between “flawless” and “internally flawless”.

A.5 For clarity determination, surface grain lines shall be taken into consideration, only to distinguish between “flawless” and “internally flawless”.